



System Type Approval Certificate

Certificate Number *jhai 14021*

jhai
limited

This is to certify that the

DURABASE

BUILDING SYSTEMS

Floor and dwarf wall system provided by

Durabase

Wye Valley Engineering Ltd
Durabase House
Netherwood Road
Rotherwas Industrial Estate
Hereford HR2 6JU

Meets the technical requirements of the elements of the Building Regulations 2010 (as amended) specified in the attached schedule

Date of Issue

19/01/2017

Date of expiration

19/01/2019

Signed on behalf of jhai Ltd

Andrew Crooks

Director of Technical Services & Learning

Offices throughout the UK



Regulated
by RICS

Alternative format or larger text available

Registered Office: Whitelcross Business Centre, Netherbury, Dorset, DT6 5NH
Company Reg No 3980572, VAT Reg No 730 3156 71





System Type Approval Schedules

Certificate Number jhai 14021

For

DURABASE
BUILDING SYSTEMS

Floor and dwarf wall systems

Provided by

Durabase

Wye Valley Engineering Ltd
Durabase House
Netherwood Road
Rotherwas Industrial Estate
Hereford HR2 6JU

System Type Approval Schedules



Contents

1.	Summary	4
2	Product Description.....	5
3	Approval Statement.....	7
4	Conditions of Use.....	8
5	Extension Guidance	9



1. Summary

- **Durabase** is a floor and dwarf wall system for use as a base for Orangeries and single storey home extensions.
- The purpose of this assessment is to determine that the system complies with the functional requirements of the relevant sections of the Building Regulations 2010 (as amended). Note that this assessment is in respect of the bespoke steel base and modular wall system only and does not consider whether the overall extension is exempt from, or compliant with, the provisions of the regulations. Individual assessment of the ground conditions and base construction are excluded and will be assessed on a site specific basis using industry standard codes
- In support of this process Wye Valley Engineering Ltd. have provided the following documentation for assessment and review
 - **Structural engineer's calculations/design**
 - **U Value calculations by Recticel dated April 2011 (Floor) & by Knauf Insulation dated January 2014 (Walls)**
 - **25 year guarantee certificate**
 - **British Board of Agreement Certificate No. 08/4525**
 - **Durabase promotional brochure**
 - **Detail drawings**

Building Regulations 2010 Technical Requirements

<p>Requirement A1</p> <p>Comment</p>	<p>Loading</p> <p>The system meets the requirement to safely sustain the relevant loads applied to it. The installer must however satisfy themselves as to the adequacy of the existing structure. Individual assessment of the ground conditions and base construction are excluded and will be assessed on a site specific basis using industry standard codes</p>
---	---

<p>Requirement B4(2)</p> <p>Comment</p>	<p>External fire spread</p> <p>The dwarf wall should be considered as an unprotected area.</p>
<p>Requirement C2</p> <p>Comment</p>	<p>Resistance to moisture</p> <p>The system meets the requirement to resist precipitation, surface and interstitial condensation.</p> <p>To provide adequate air flow beneath the floor a minimum 150mm air gap between the ground and the underside of the base must be ensured. The ground should be covered so as to resist moisture and prevent plant growth.</p> <p>Air vents must be fitted to the fascia skirting board on both ends of the base to ensure adequate cross ventilation under the floor. The openings should be not less than either 1500mm²/m run of external wall or 500mm²/m² of floor area, whichever gives the greater opening area.</p>
<p>Requirement L1</p> <p>Comment</p>	<p>Conservation of fuel and power</p> <p>The system meets the requirement to limit heat loss through the floor and dwarf wall construction.</p>

2. Product Description

- **Durabase** by Wye Valley Engineering Ltd. Is a bespoke system comprising of a rigid steel base frame with screw adjustment levelling feet which stand on concrete pads and provide a base for orangeries and extensions
- The base frame supports a galvanized steel modular dwarf wall system with a selection of brick slip finishes
- These systems can be designed as a bespoke structure to suit the existing dwelling
- The Durabase products comprise of the following

- Full height base system
 - Modular wall base system
 - DurabasePlus Modular wall/full height base system
- When using the DurabasePlus system the specially designed steel base and flooring insulation can achieve a U-value of 0.22 W/m²K. The modular walls, when insulated and finished off with foil-backed plaster board can achieve a U-value of 0.27 W/m²K
 - The three extension types have been marketed and can be described as follows

Full Height Base System

Standing on concrete pads and bolted to the house wall. The building system fits directly to the outer beam of the base and is completed with an insulated floor. The exterior of the base is finished with a plain or brick clad skirt.

Modular Wall Base System

The wall consists of a strong galvanised frame with specially profiled building board onto which genuine clay brick tiles are bonded to give a tough, lightweight brick wall system. The frames are pre-clad and pre-pointed; leaving the bridging tiles to be inserted over the frame joins. The hollow frame can conceal plumbing, electrical cables and insulation material. This system along with the Pre-fabricated base system is delivered to site readymade.

DurabasePlus Modular Wall/Full Height Base System

The Durabaseplus has all the advantages of the Durabase System but with the capability of achieving an even greater U-value. The specially designed steel base and flooring insulation can achieve a U-value of 0.22 W/m²K. The modular walls, when insulated and finished off with foil-backed plaster board can achieve a U-value of 0.27 W/m²K.

3 Approval Statement

3.1 Upon review of the details submitted the **Durabase System is hereby approved for compliance** with the referenced functional requirements as cited in Schedule 1 of the Building Regulations 2010 for residential use (purpose groups 1 (a)(b)(c) in Table D1 of Approved Document B:2006) where used as a domestic extension

3.2 This certification is issued to and is approved for use by

Durabase

Wye Valley Engineering Ltd
Durabase House
Netherwood Road
Rotherwas Industrial Estate
Hereford HR2 6JU

When submitted as a valid building regulation application to **jhai ltd.**

3.3 The technical standards referred to for the purpose of this assessment are as follows:

3.3.1 Durabase bespoke steel base system

3.3.2 Durabase modular wall system

3.4 **IDENTIFICATION AND USE OF THE JHAI LOGOS**

Correct identification of approved Building Systems is desirable in order that purchasers and funding providers understand the status of products presented to them.

Recipients are encouraged to make use of the **Jhai System Approval Logo** on marketing and technical documentation

4 Conditions of Use

- 4.1 The **Durabase** System as assessed by this process is suitable for use as an extension to a single or multi occupancy residential buildings. The details and information contained within this approval may be suitable for buildings in other purpose groups where appropriate and upon further consideration and assessment by Jhai
- 4.2 The approval covers the elements of the superstructure only as contained in the technical standards referred to in item 3.3 above. Individual assessment of the ground conditions and base construction are excluded and will be assessed on a site specific basis using industry standard codes.
- 4.3 Indicative guidance relating to the construction of traditional elements of the work is contained in Section 5
- 4.3 Any element outside the scope of this approval shall be assessed for each use on site and any variations from either **Durabase** or **Building Regulations** (and associated) standards shall be assessed by a competent and qualified structural engineer experienced with the **Durabase** systems
- 4.4 This system approval relates to the **Durabase** system as described in the technical guides referenced in 3.3 above. It is subject to the same exclusions contained therein and all other components and working practices are subject to the requirements of the Building Regulations, manufacturers installation guides and associated standards
- 4.5 This is a pre-fabricated system and as such annual assessment of **Durabase** QA process will be carried out as part of the technical audit for the **Durabase** product.
- 4.6 An assessment of the QA process between **Durabase** and the installers will be carried out as part of the inspection programme to demonstrate that the components are being used in accordance with **Durabase** recommendations. This is in addition to the site visits required to demonstrate compliance with the Building Regulations and associated standards
- 4.7 No cutting or alteration of the structural members on site are permitted without obtaining written approval from **Durabase**
- 4.8 The component systems referenced are constructed/manufactured in factory conditions and as such is designed to be erected within a short period of time. Construction should be continuous and preferably scheduled during periods of sustained dry weather through to the provision of the permanent roof covering as soon as reasonably possible.

- 4.9 Each extension will need to be appraised individually for compliance with the Building Regulations 2010 by jhai based upon the guidance contained in the current Approved Documents
- 4.10 An assessment as to whether the external cladding achieves a Class 0 (or classB-s3, d2) will be carried out on an individual basis based upon the site specific cladding/infill panel selection
- 4.11 The external cladding and glazed area will be assessed for each individual project based upon the specified materials (unprotected areas) and boundary locations as referenced in Section 5 of these schedules
- 4.12 The system approval is limited to single storey buildings and as such fire resistance test standards of Part B of the Building Regulations and BS 476: Parts 20, 21 and 22 (as appropriate) will not be applicable.
- 4.13 Where the thermal separation is removed between the host structure and the Durabase structure, the glazed area of the extension should ordinarily be limited to 25% of the floor area + the area of any existing windows/doors enclosed by the extension.
- 4.14 Where the requirements of 4.13 is exceeded SAP calculations will be required. SAP calculations look at the whole building as extended and will require a more detailed survey to be undertaken
- 4.15 This system approval certificate is valid for a period **of two years** from the date of issue. This limitation is placed in order that the impact of new and changing relevant regulation can be assessed prior to re-issue
- 4.16 Note that this is a system approval of the **Durabase** products only and additional site specific information may be requested that is not encompassed by the detail contained in the approval.

Signed on behalf of jhai Ltd.



Andrew Crooks

Director of Technical Services & Learning

5 Extension Guidance

5.1 Introduction

The following is considered general guidance for construction work. It is accepted that there are other alternative methods of construction and Jhai will happily review such details if required

5.2 Pad foundation

Pad foundations should be taken down into firm natural ground and are generally at least 450mm deep but other factors will be taken into account such as;

- The type of subsoil
- Presence of trees/roots
- Location and invert of drains

On clay, sand or peaty subsoil further excavation will be required.

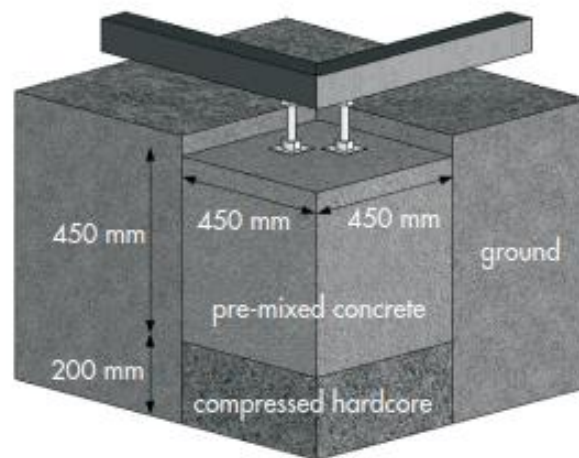

Part A (Structure) of the building regulations gives further guidance for the design of foundations, however it is acknowledged that this is based upon the support of a 2.5 storey domestic type structure. If you require further pragmatic guidance please contact a member of the Jhai team

5.3 Foundations and existing drains

Jhai requirement is to ensure that the drain complies with Part H of the Building Regulations. One consideration is to ensure that the excavations do not surcharge any drain running under or close to the extension

Drains running under and through the foundation must be isolated from the foundation with shuttering. Existing Inspection chambers within the footprint of the extension are technically permissible under Building Regulations with the installation of a room sealed cover. However this may not be permitted by the water authority (see 5,7)

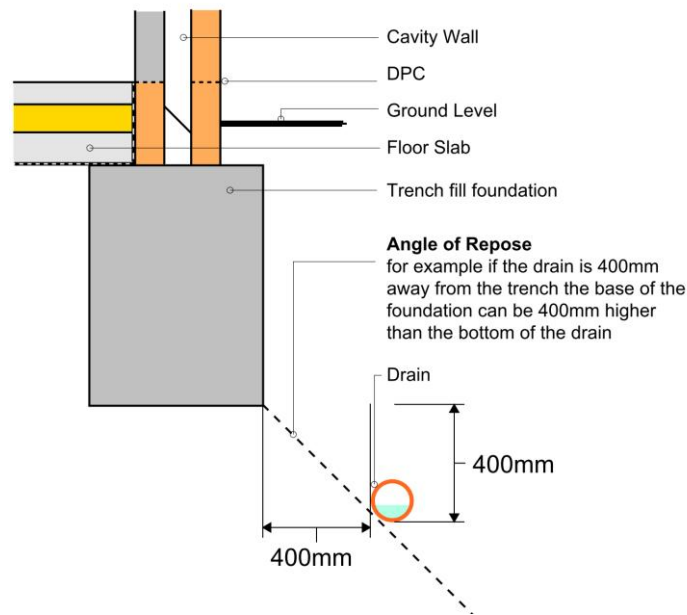

5.4 Drainage

It should be assumed that drainage systems serving more than a single dwelling are the responsibility of the sewerage undertaker. Upon appointment Jhai are obliged to notify the same of the work whereupon they will make contact with the contractor/client

Drainage is usually separated into foul water and rainwater drainage – ideally points of disposal should also be separate. Rainwater drainage should discharge to a new soakaway sited more than 5m from any building. The subsoil should be suitable for percolation drainage, where this is not possible or practicable connection into either a surface water sewer or combined sewer may be unavoidable.

The foul water should connect into the existing system – if as described previously the connection is via a new connection onto the public sewer then the Water Authorities consent may be necessary. It is worth noting that limits of cover (on top of the pipe) will determine bedding requirements – any pipe less than 600mm deep in gardens and 900mm deep in driveways will require protective bedding and cover in the form of concrete

5.5 Ground Floor

The ground floor of your extension performs a number of tasks: it must keep out damp, provide a structural base and provide thermal insulation. Generally a ground floor is a multi-layered structure, the top soil under the extension is removed and a layer of compacted stone is placed over the site. This is covered or "blinded" with sand and a layer of 1200g polythene is then placed over the sand and lapped with the damp proof course in the wall. A layer of insulation (typically 100mm of Celotex, Kingspan or similar) is then provided and a concrete slab at least 100mm thick is poured over the insulation. This concrete can be float finished or a sand/cement screed applied at a later date to provide the finished internal floor. Variations on this general arrangement are as follows,

Solid Floor – As described above. Finally, the floor is finished with a layer of wood (floating floor finish) or screed. If screed is used, it should be around 75mm thick to avoid cracking. Alternatively the insulation can be placed under the screed by following the insulation manufacturers details/specification

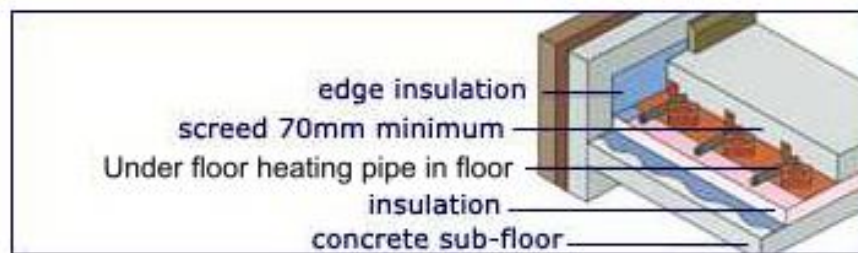

Suspended Timber Floor - Timber joists are laid from wall to wall with a minimum gap of 150mm maintained between the underside of the floor joists and the concrete floor. A dpc should be laid underneath the timber floor and a cross flow of air, on opposing elevations, should be achieved. Insulation can be placed between the joists.

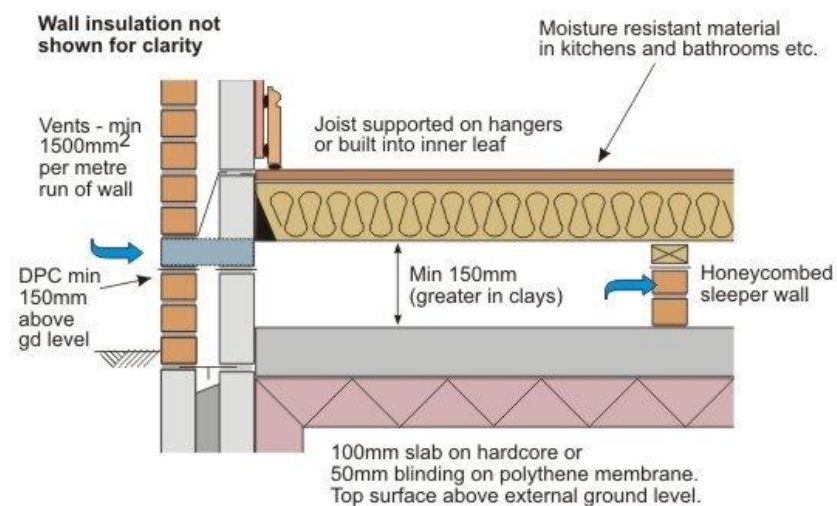

Battened solid – This method involves fixing timber boarding onto treated timber battens plugged and screwed into a concrete slab beneath. Insulation can be placed between the battens (fully filling the void) with a vapour check over.

It is worth noting that the damp proof layer in some instances can also act as a barrier to contaminants – again any preliminary investigative work will identify if any contaminants are present (e.g. radon or methane)

Durabase base frame section – The Durabase base frame stands on concrete pads and the frame is bolted to the house wall. This method eliminates the necessity for traditional foundations.



5.6 External Wall Construction

Cavity wall – The wall should incorporate a dpc that is lapped to the damp proof membrane in the floor and to the existing DPC at junctions. The cavity should extend to at least 225mm below the DPC. The masonry must be tied to the existing by tooth bonding or proprietary stainless steel fixing profiles. A typical wall construction would comprise of 100mm blockwork, 100mm cavity with full or partial fill insulation and 100mm lightweight blockwork.

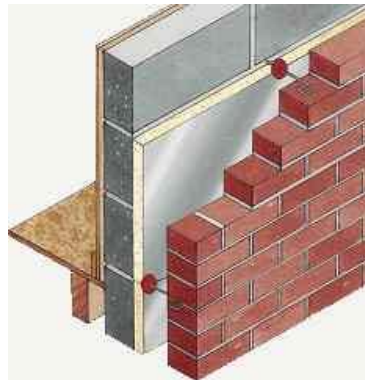

Durabase galvanized steel modular dwarf wall system – Consisting of a three part outer layer (Brick slip, high density insulation board, structural ply backing panel) and a galvanised steel frame with holes pre-cut to provide access for wiring and plumbing.

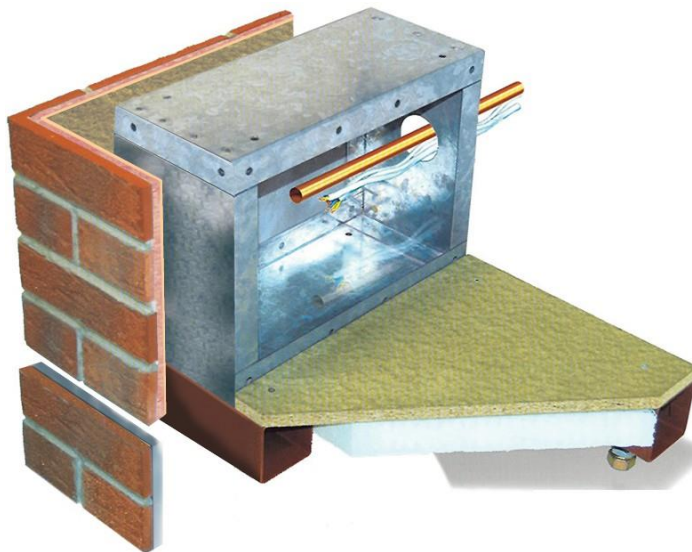

5.7 Windows / Ventilation

As a general guidance, glazing should not form more than 25% of the proposed floor area less any windows / openings lost at the abutment of the extension. However the **Durabase** system allows an increase in these areas using the SAP method of calculation (see 4.14 above).

Trickle ventilation of around 8,000 mm² should be provided to each habitable space. This could be in the form of windows that lock in the open position but will be subject to review on a case by case basis

Care should be taken if the extension covers the only window or door providing ventilation to another habitable part of the house (i.e. bedroom; lounge; Dining; etc). In this case alternative provision of both Background (trickle) and Purge (openable window) should be provided to the room

In this case means of escape from the room being enclosed may also be compromised – please speak to Jhai in this instance

Mechanical ventilation is required to non- habitable rooms such as Kitchens, Utility, Bath/Shower Rooms, WC's and Ensuite's formed as part any extension; or made worse by the proposals – if these rooms are windowless then over-run provision will need to be made to the extraction

5.8 Openings on Boundaries

There are limits as to the amount of openings permitted close to any boundary. The purpose of this is to prevent fire from spreading to adjoining property/land. If you are less than 1m from the boundary the maximum area permitted is 1.0m²

The further away you are the larger the openings can be. This can be expressed as either a physical area in m² or as a percentage of the wall. The diagram below provides some guidance but as always there are other methods of calculation so speak to Jhai for more specific case by case advice

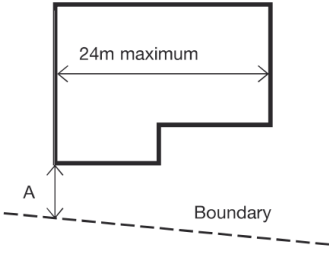
		Minimum distance between side of building and relevant boundary (m)	Maximum total percentage of unprotected area %
		1 2.5 5 7.5 10 12.5	8 20 40 60 80 100
Minimum distance (A) between side of building and relevant boundary (m)	Maximum total area of unprotected areas (m²)	Notes:	
1 2 3 4 5 6	5.6 12 18 24 30 No limit	a. Intermediate values may be obtained by interpolation. b. For buildings which are fitted throughout with an automatic sprinkler system, see para 9.15. c. The total percentage of unprotected area is found by dividing the total unprotected area by the area of rectangle that encloses all the unprotected areas and multiplying the result by 100.	